



BESCHLÄGE FÜR FALTSCHRANKTÜREN

Für Schränke mit Aluminium- und/oder Holztüren.

1 FALTTÜRSYSTEM	522
■ Profile und laufwagen	522
■ Scharniere	523
■ Technische daten	524

1 FALTTÜRSYSTEM

Profile und Laufwagen

Obere Laufschiene

	Sonderlänge	2m Profil	3m Profil	6.1m Profil	
Silber mat eloxiert	710.901.516*	710.921.514	710.931.513	710.961.510	20
Naturbelassen	710.901.505*	710.921.503	710.931.502	710.961.506	
Silber glänzend eloxiert	710.901.100*	710.921.105	710.931.104	710.961.101	
Weiß lackiert RAL 9010	710.901.800*	710.921.805	710.931.804	710.961.801	

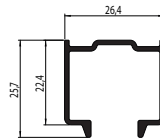

* Mindestbestellmenge 120 Stück.

Oberer Laufwagen

Befestigung in	Holz	Aluminium	
	344.021.020	344.041.025	50

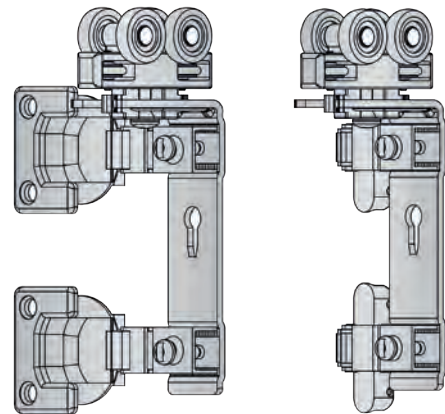
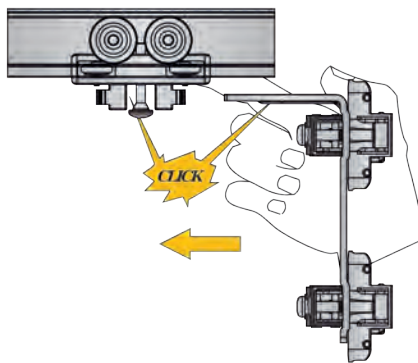

Untere Laufschiene

	2m Profil	
Silber eloxiert	711.500.101	20
Naturbelassen	711.500.506	

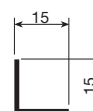

Unterer Laufwagen

Befestigung in	Holz	Aluminium	
	343.707.066	344.407.066	50

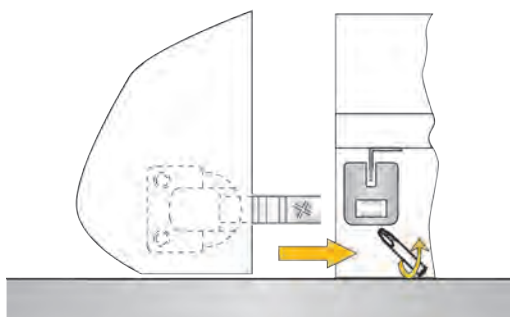
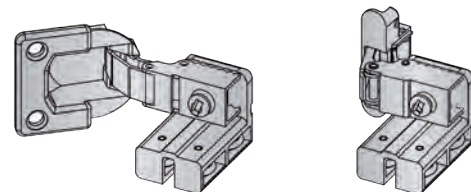

■ Scharniere

Scharnier Aluminium-Aluminium

		
Vernickelt	344.130.065	50

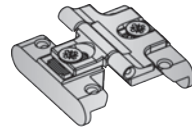

Scharnier Holz-Aluminium.

		
Vernickelt	344.140.064	50

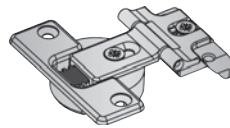

Scharnier Holz-Aluminium.

		
Vernickelt	344.150.063	50

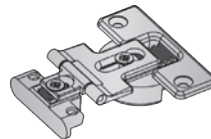

Scharnier Holz-Holz.

Zinkdruckguß		
Vernickelt	344.100.061	50

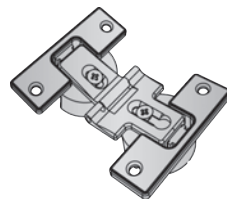

Scharnier Holz-Holz.

PA		
Schwarz RAL 9005	344.110.023	150
Grau Ral 7040	344.110.314	

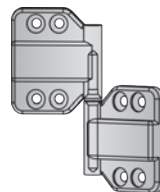

Beschlagset

		
	702.910.106	10

Anzahl der Elemente pro Set: 1 oberer Laufwagen, 1 unterer Laufwagen und 3 PA Scharniere

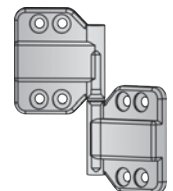
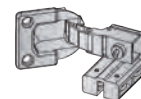
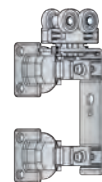

Oberer Laufwagen

Unterer Laufwagen

Scharnier

■ Technische Daten

Mögliche Türkombinationen.

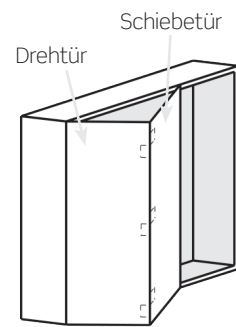

Aluminium - Aluminium



Holz - Aluminium



Aluminium - Holz



Holz - Holz (Zinkdruckguß-Scharniere)



Holz - Holz (PA -Scharniere)



■ Technische Daten

Bohrbild

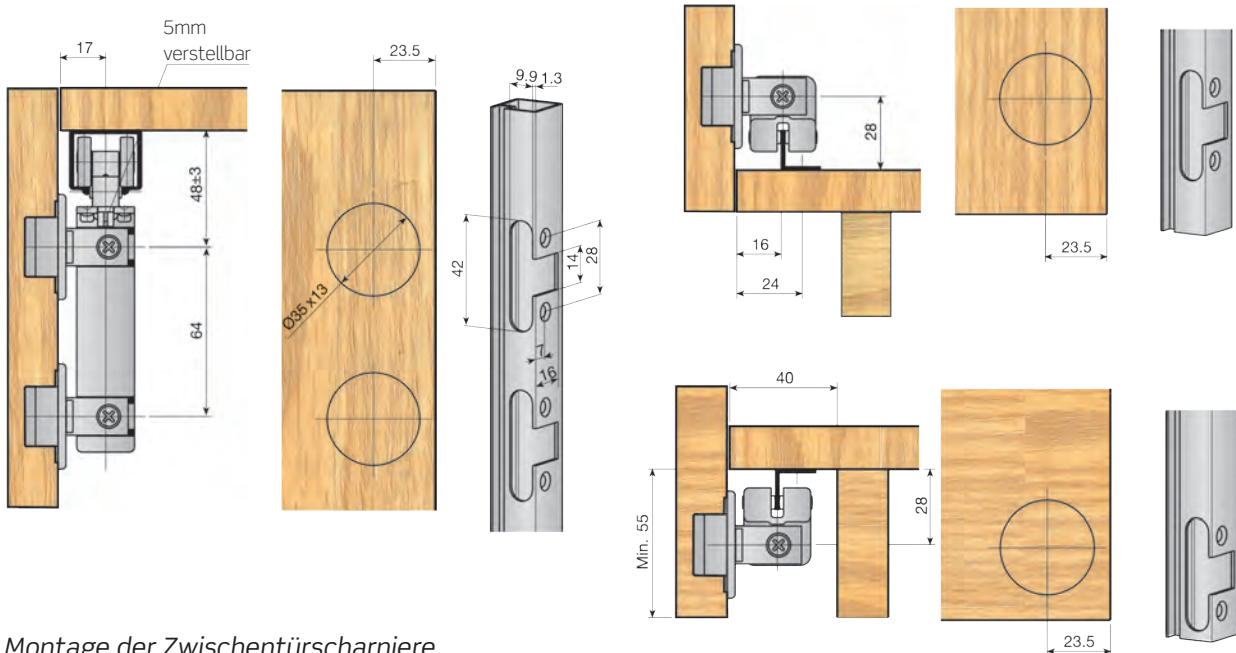

Montage der Zwischentürscharniere

Scharniere aus ZAMAK

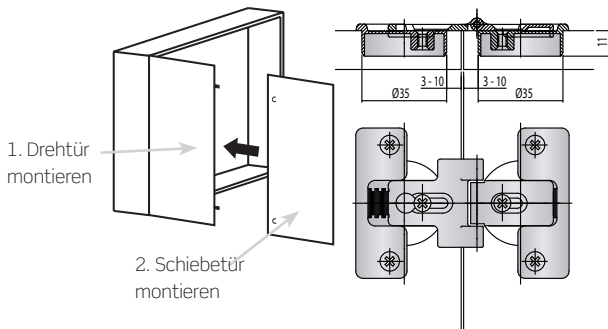

Scharnier aus PA

Positionierung der Schiebetürscharniere über denen der Drehtür.

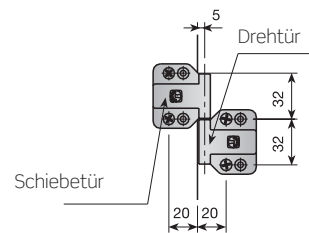

Innenansicht

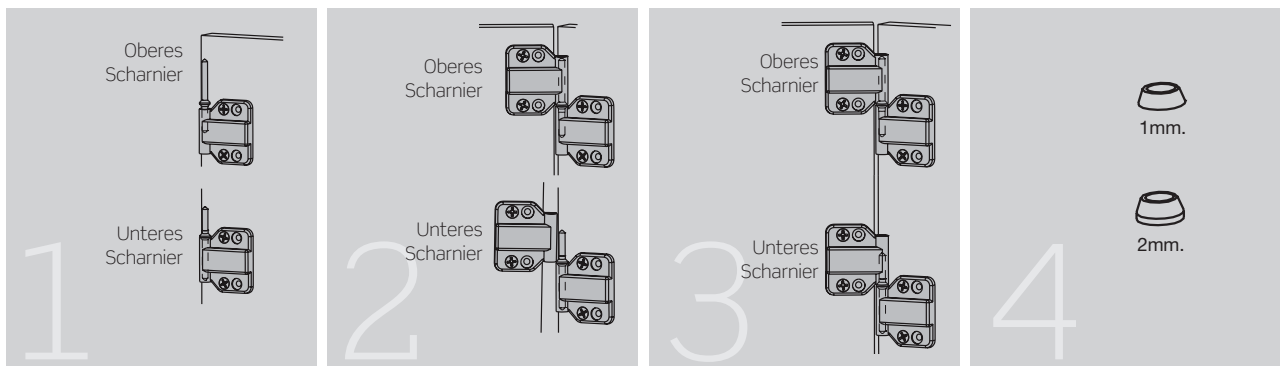

Positionierung der Achsen:
Einsetzen der kürzen Seite der Achse in das obere Scharnier.
Einsetzen der längeren Seite der Achse in das untere Scharnier.

Positionieren der Schiebetür: Nur das obere Scharnier auf.

Montage der Tür:
Ausrichten der Tür mit Hilfe der oberen Scharnierachse, so daß das untere Scharnier auch der Linie mit der Achse liegt. Tür fallen lassen. Sie rastet automatisch ein.

Für eventuelle:
Höhenverstellungen bitte Unterlegscheiben verwenden.