



FERRURES POUR PORTES PLIANTES

Pour portes d'armoires ou de placards en aluminium et/ou bois.

1 SYSTÈME POUR PORTES PLIANTES.....	522
■ Profils et chariots	522
■ Charnières	523
■ Spécifications techniques.....	524

1 SYSTÈME POUR PORTES PLIANTES

■ Profils et chariots

Profil supérieur Aluminium

	Sur mesure	Barres de 2m	Barres de 3m	Barres de 6.1m	
Anodisé argent mat	710.901.516*	710.921.514	710.931.513	710.961.510	20
Naturel	710.901.505*	710.921.503	710.931.502	710.961.506	
Anodisé argent brillant	710.901.100*	710.921.105	710.931.104	710.961.101	
Laqué blanc ral 9010	710.901.800*	710.921.805	710.931.804	710.961.801	

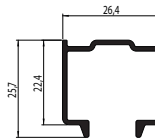

* Commande minimum: 120unités.

Chariot Supérieur

Pour porte de	Porte Bois	Cadré Aluminium	
	344.021.020	344.041.025	50

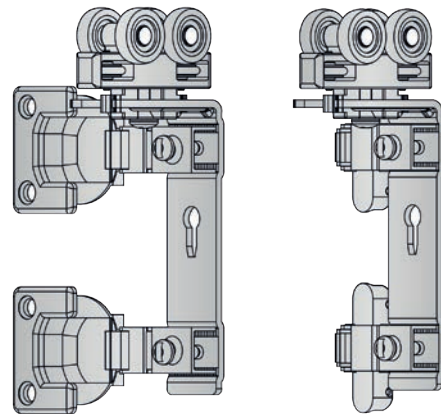
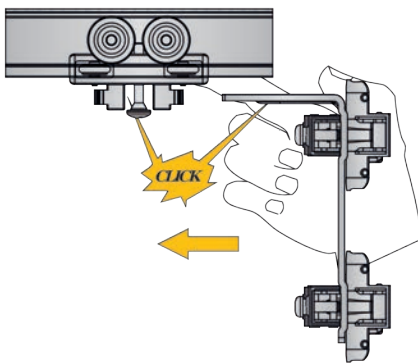

Profil inférieur Aluminium

	Barres de 2m	
Anodisé argent	711.500.101	20
Naturel	711.500.506	

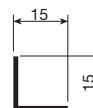

Chariot inférieur

Pour porte de	Porte Bois	Cadré Aluminium	
	343.707.066	344.407.066	50

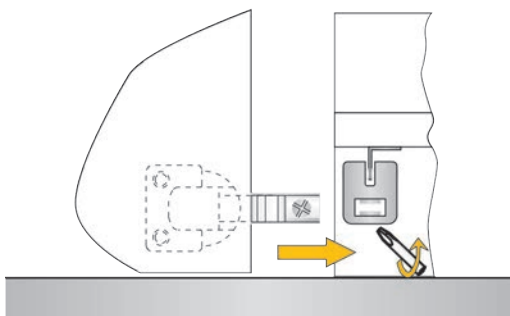
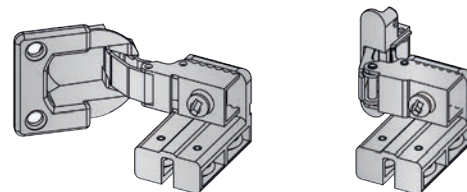

■ Charnières

Charnière intermédiaire Aluminium-Aluminium

		
Nickelé	344.130.065	50

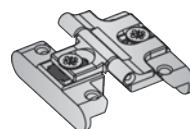

Charnière intermédiaire Bois-Aluminium

		
Nickelé	344.140.064	50

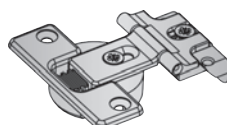

Charnière intermédiaire Aluminium-Bois

		
Nickelé	344.150.063	50

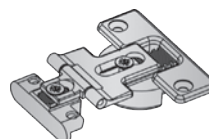

Charnière intermédiaire Bois-Bois

Zamack		
Nickelé	344.100.061	50

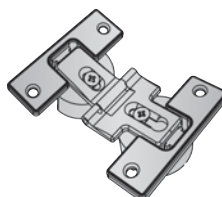

Charnière intermédiaire à visser Bois-Bois

PA		
Noir RAL 9005	344.110.023	150
Gris RAL 7040	344.110.314	

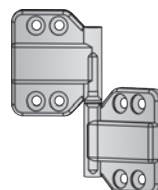

Sachet de ferrures

		
	702.910.106	10

Contient 1 chariot supérieur, 1 chariot inférieur et 3 PA charnières

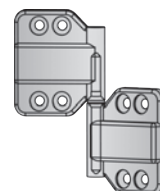
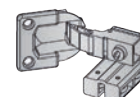
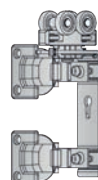

Chariot supérieur

Chariot inférieur

Charnière

■ **Spécifications techniques**

Combinaisons de portes: possibilité de combiner des portes en aluminium et des portes en bois. Nous sera utile pour le choix de la charnière intermédiaire.

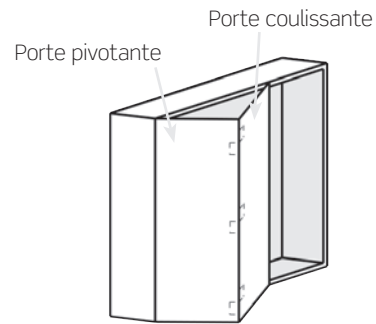

Aluminium - Aluminium Charnière Zamack 344.130.065

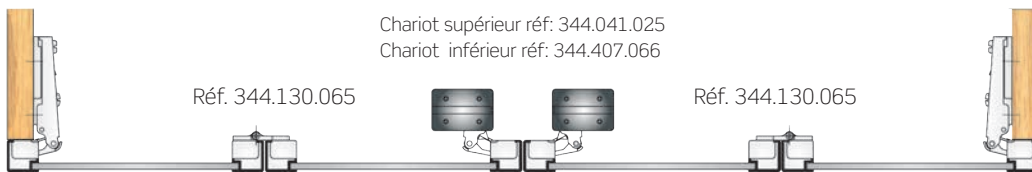

Bois - Aluminium Charnière Zamack 344.140.064

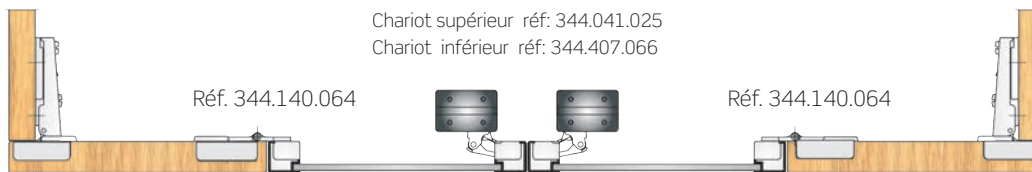

Aluminium - Bois Charnière Zamack 344.150.063

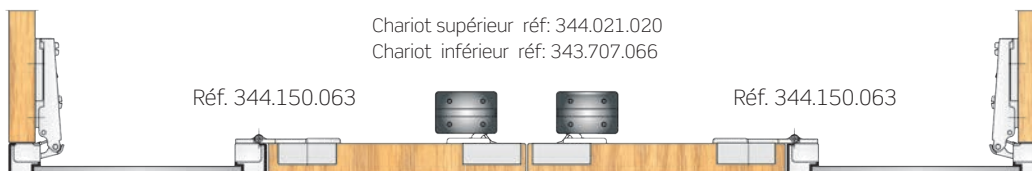

Bois - Bois Charnière Zamack 344.100.061



Bois - Bois Charnière PA 344.110.023

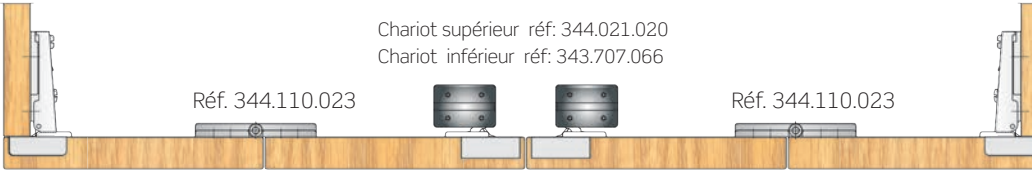

■ Spécifications techniques

Logement des ferrures

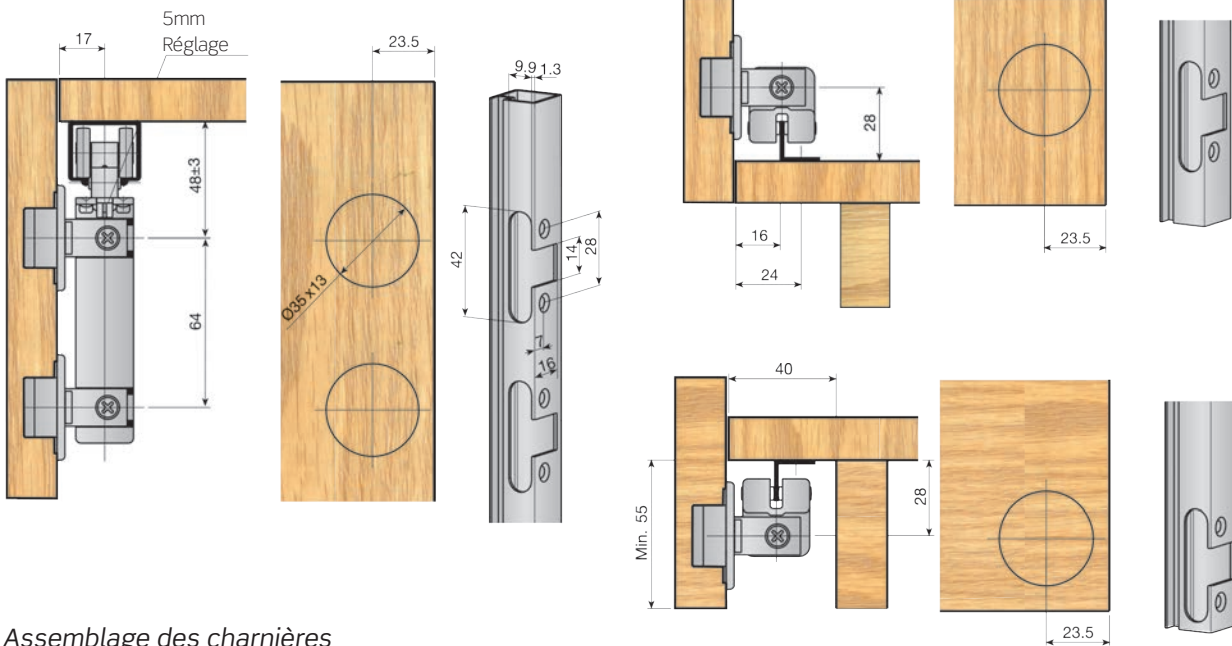

Assemblage des charnières

Assemblage de charnière ZAMACK

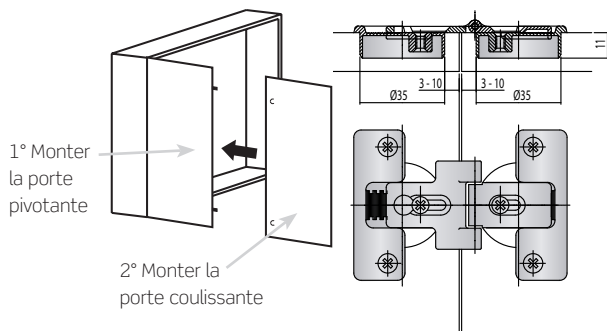

Assemblage de charnière PA

Les charnières de la porte coulissante se attachent par-dessus celles de la porte pivotante.

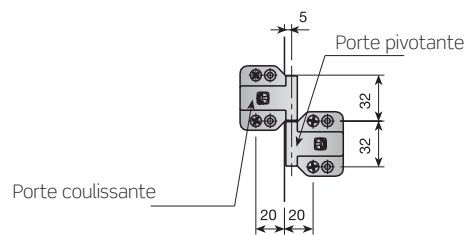

Vue intérieure de l'armoire

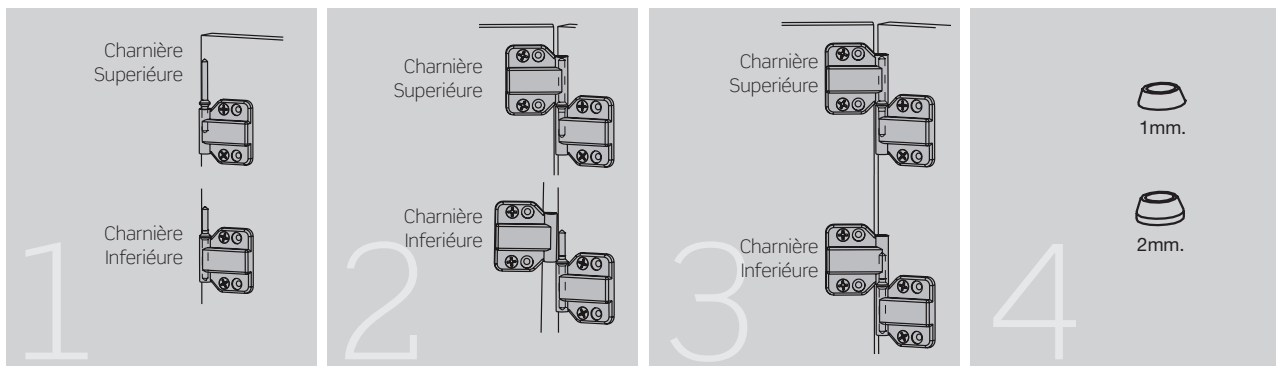

Fixer les axes:

Introduire le coté de l'axe le plus court dans la charnière supérieure. Introduire le coté de l'axe le plus long dans la charnière inférieure

Fixer la porte coulissante: placer uniquement la charnière supérieure.

Aligner les 2 portes: En s'aidant de l'axe de la charnière supérieure, remonter la porte jusqu'à obtenir l'alignement des charnières inférieures avec leurs axes. Descendre ensuite la porte qui s'engage automatiquement sur la charnière inférieure.

Reglage:

Utiliser les rondelles fournies avec la charnière.